



# TECNA

Tecnología de aislamientos  
y climatización, S.L.

## AIRGROUP

A u s t r a l i a

### COOL BREEZE

## LISTA DE RECAMBIOS



Spare Parts List

EUROPA



MAYO 2011

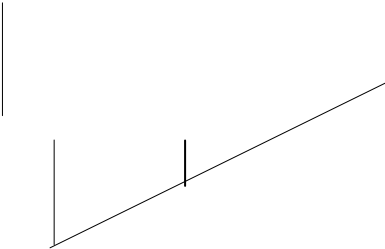
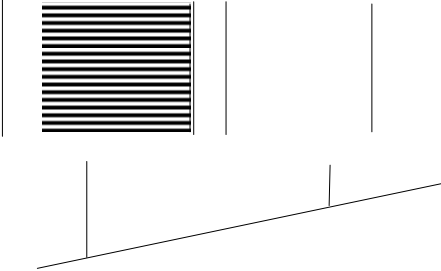

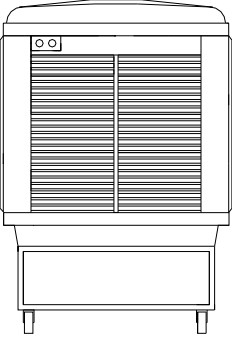
CONTENTS

		PAGE
Exploded View DOWN DISCHARGE		4
Exploded View TWIN FAN D 500		5
Exploded View SIDE DISCHARGE S240 SIDE DISCHARGE S100		6 & 7
Exploded View MOBILE M240		8

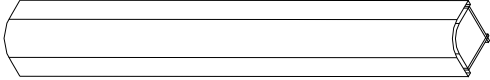
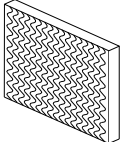
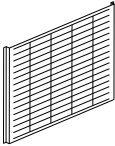
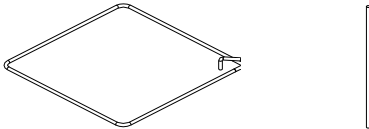
## CONTENTS

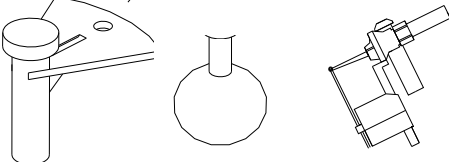
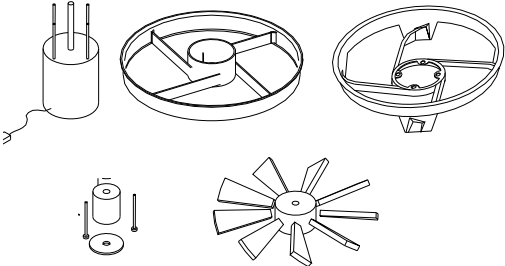
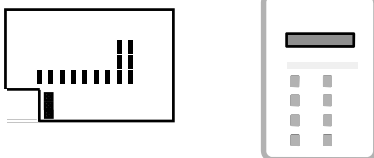

		PAGE
CORNER POSTS (POSTES LATERALES, DE ESQUINA)		9
FILTER PADS (Filtros de carton celdek)		12
LOUVRE PANELS (Rejillas de proteccion)		13
WATER DISTRIBUTION PARTS (Piezas de la Distribucion de auua) WATER FEED PIPES (Tubo de alimentacion de agua)		14
WATER INLET & DISTRIBUTION PARTS (Piezas de la toma y distribucion de agua)		14
FLOAT VALVE & ACCESSORIES (Flotadores y accesorios)		15
FANS, COLLETS & MOTORS (Ventiladores, motores y sus accesorios)		17/18
CIRCUIT BOARDS, CONTROLLERS & CABLES (Circuitos electronicos y cuadros de control)		19/20/21

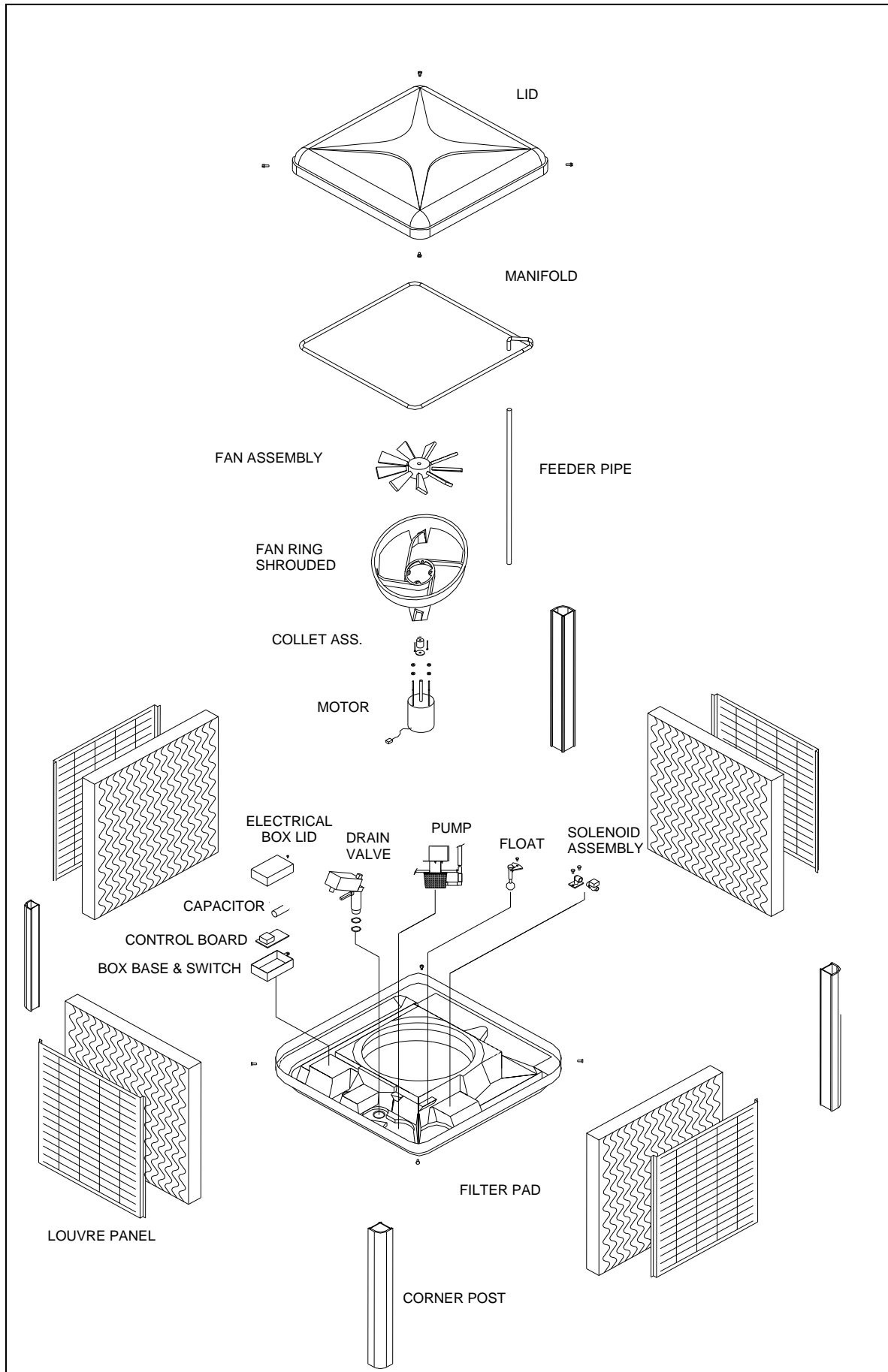
# EXPLODED VIEW DOWN DISCHARGE AIR CONDITIONING UNIT

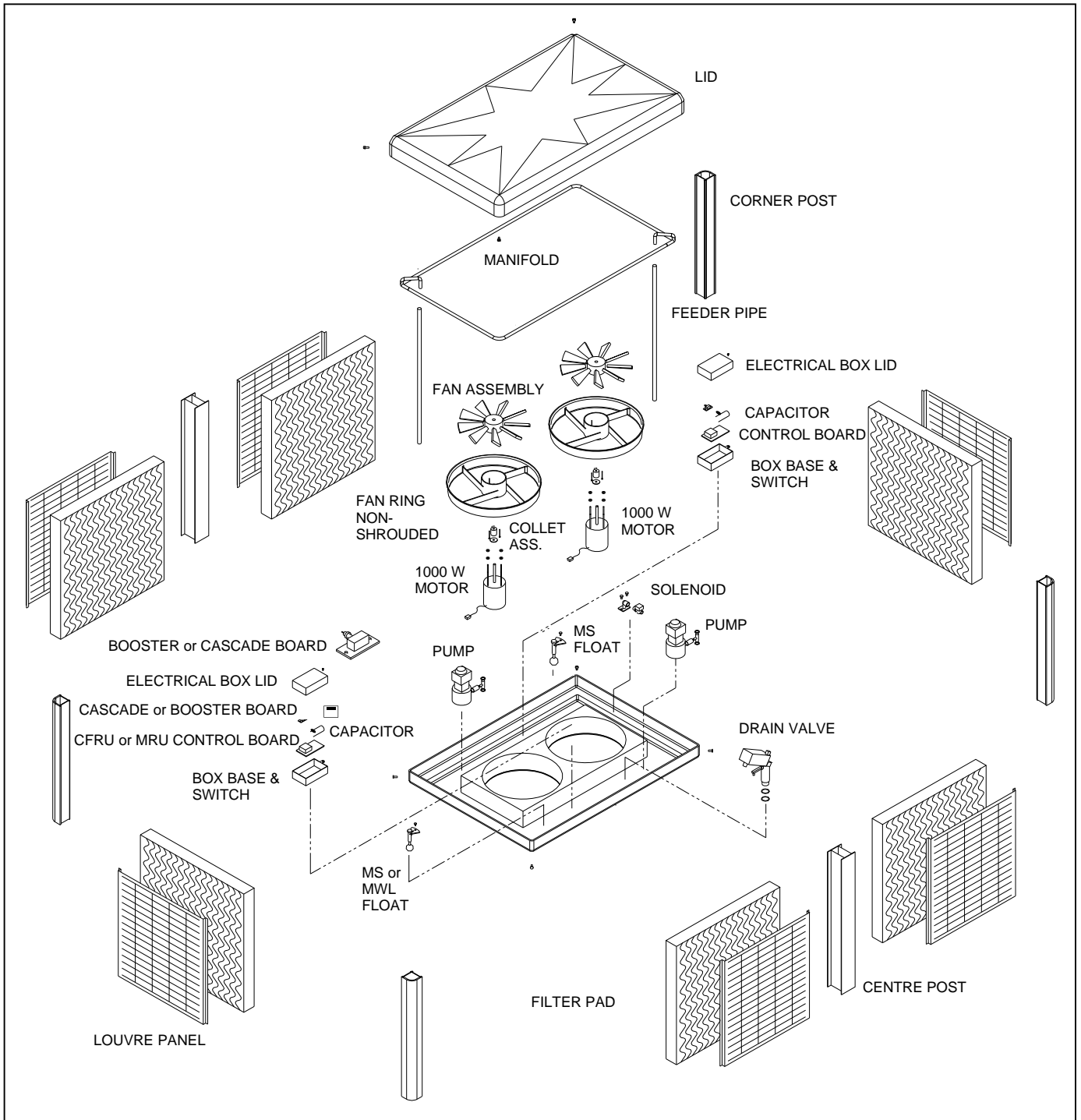

# EXPLODED VIEW TWIN FAN DOWN DISCHARGE (D500) AIR CONDITIONING UNIT

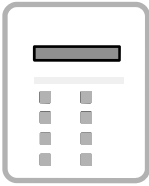
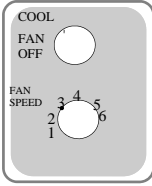

QAD500 SERIES	FD500 SERIES
QA KEYPAD 	R KEYPAD 
Roof Unit = MRU	Roof Unit = CFRU
Signal Amplification = Cascade PCB 	Signal Amplification = Booster PCB 
250mm Cascade Board to MRU connecting cable	No connecting cable required
Water Inlet = MS Float x 2	Water inlet = MWL Float x 1

EXPLODED VIEW SIDE DISCHARGE (S240) AIR CONDITIONING UNIT

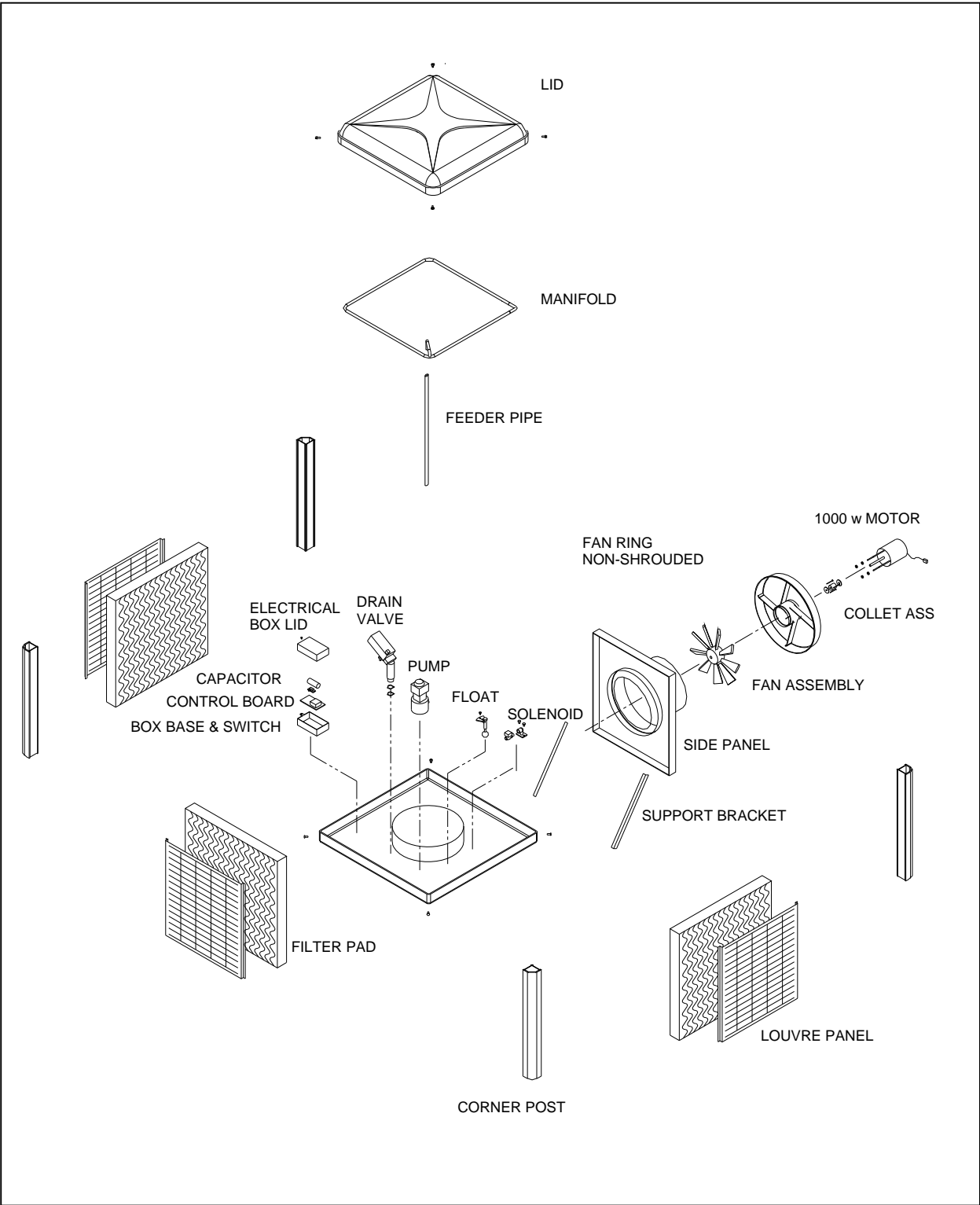

# EXPLODED VIEW SIDE DISCHARGE S100 AIR CONDITIONING UNIT

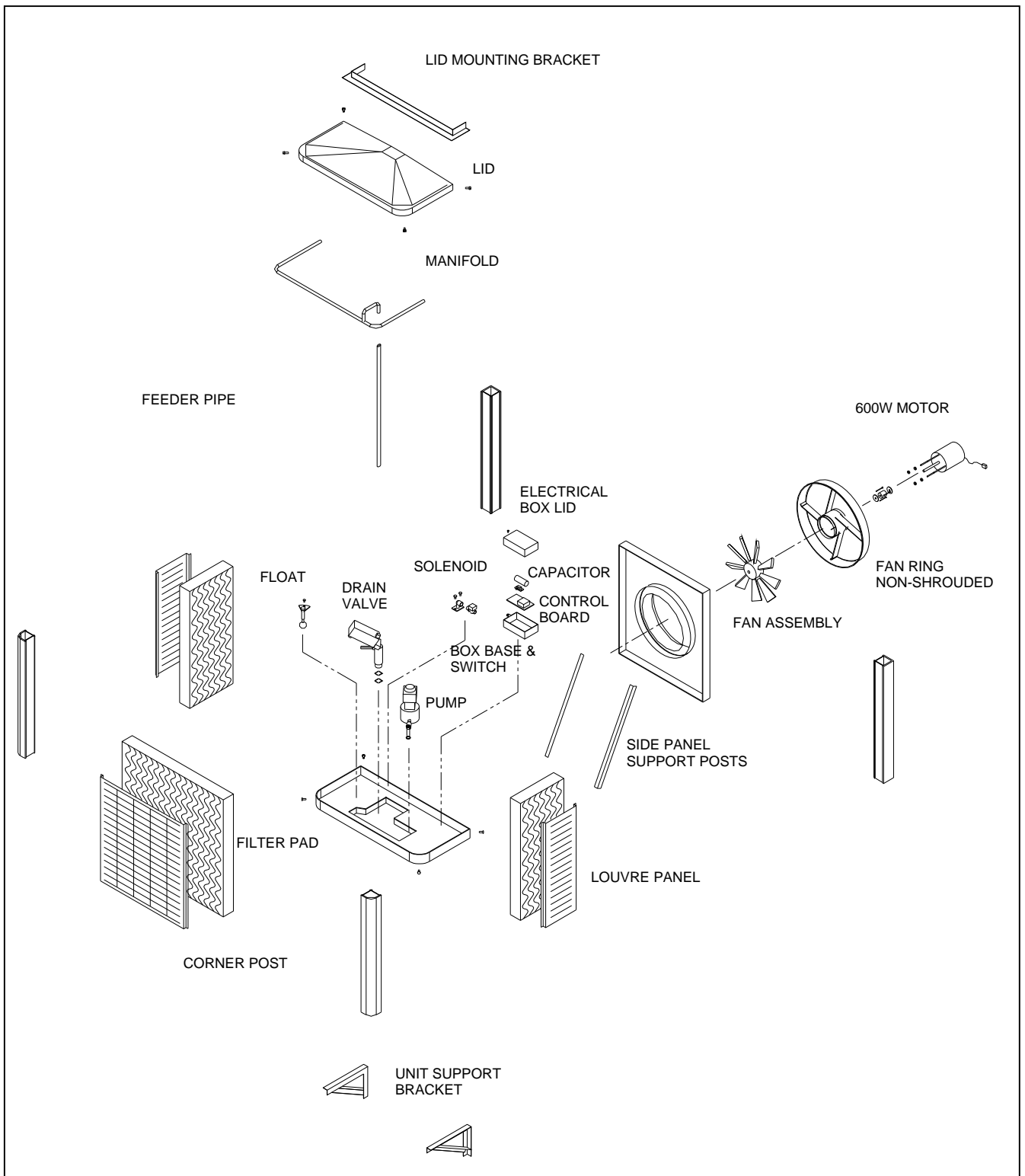

# EXPLODED VIEW MOBILE (M240) AIR CONDITIONING UNIT

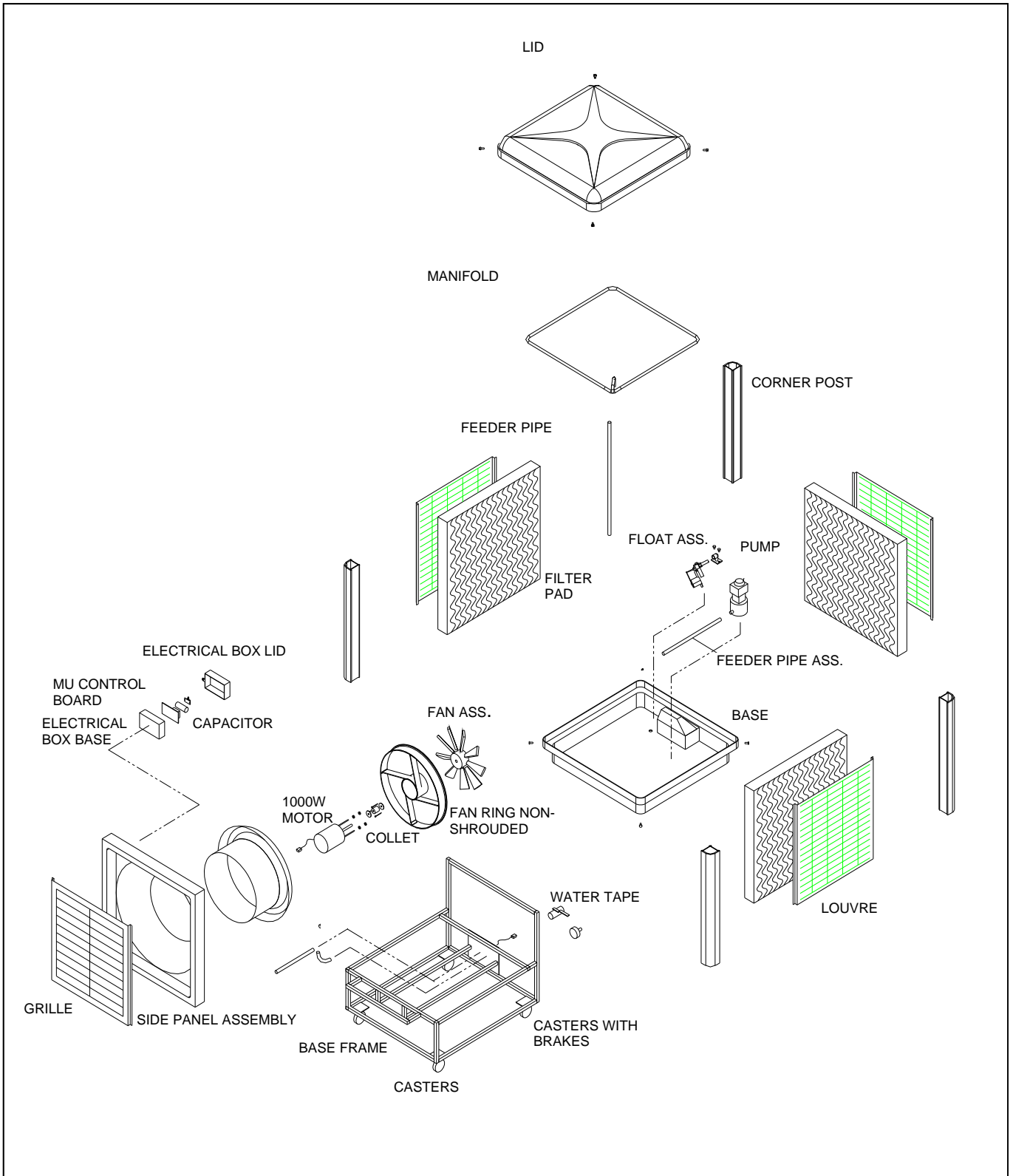

**CORNER POSTS (POSTES LATERALES, DE ESQUINA)- Specify Colour**  
**Precios Unitarios/INDIVIDUALLY PRICED**

Manufactured	Model	Description	Part No.	Exploded view Reference
1994 - 2000 CM Series Colour Grey Color Gris	130	515mm High (inner and outer)	SP4040	
	185	650mm High (inner and outer)	SP4044	
	250/ 200S	950mm High (inner and outer) (2 piezas: interior y exterior)	SP4062	
<b>Modelo CA,</b> <b>colour Beige</b> 2000 - 2011 Con filtros de 100 mm. de espesor	D160	460mm (inner and outer) - 100mm pads	SP4070	H 3
	D255	770mm (inner and outer) - 100mm pads	SP4076	H 3
<b>TWIN FAN</b> <b>FD 500</b> <b>2004 - 2011</b>	FD500	Side corners, 960mm. high (Postes later- als)	SP4534	TF 3A
		Center Post, 955mm. high (Poste central)	SP4536	TF 10B
	FD500	Centre Support (Tubo soporte central)	SP4566	TF 10B
		Corner Post Bolt Pack (6 Bolts) (Bolsa con los tornillos)	SP4564	TF 3
<b>Side</b> <b>Discharge</b> <b>Evaporativos</b> <b>de salida la-</b> <b>teral (S)</b> 1995 - 2011	100S	930mm - 75mm channel Front (Perfil Frontal)	SP4061	S100 5A
		930mm - 75mm channel Back Left	SP4059	S100 5B
		930mm - 75mm channel Back Right	SP4057	S100 5C
2002 -2011	240S	950mm - 100mm channel	SP4063	S240 5A
<b>Mobile Unit</b> 2002 - 2011	CMP200	950mm - 75mm channel	SP4062	
2002 - 2011	M240	950mm - 100mm channel	SP4063	
2000 - 2011 Para todos los modelos simples	<b>Corner Post Bolt Pack (4 Bolts)</b> - Bolsa con tornillos de plastico para los soportes de esquina( includes 4 x 6mm stainless bolts, 4 x 8mm Polymer bolts). Specify colour.		SP4049	

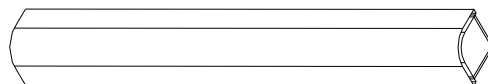

# FILTER PADS (FILTROS DE CARTON CELDEK)

Precio por cada filtro/INDIVIDUALLY PRICED

Manufactured	Model	Description	Part No.
<b>Models - CM</b> (Series with channel in top of filter pads & capping)	130	735W x 495H x 75D (Precios por cada filtro)	SP4178
	185	840W x 630H x 75D	SP4182
	250	840W x 930H x 75D	SP4186
<b>Side Dis-charge</b> <b>Salida lateral</b>	100S*	840W x 930H x 75D - Filtro frontal	SP4186
	100S	275W x 930H x 75D -Filtros laterales(2filtros)	SP4188
1995 - 2001	200S	840W x 930H x 75D - all sides	SP4186
2002 - 2011	240S	830W x 950H x 100D	SP4187
<b>Mobile Units</b> 2001 - 2002	CMP200	830W x 950H x 75D	SP4189
2002 - 2006	M240	830W x 950H x 100D	SP4187
<b>Modelos V, CA TOP Heritage</b> 2000 - 2011 <b>FD 500 Twin Fan</b> (Ileva 2 filtros Laterales + 4 frontales) 2003 – 2011	D160	830W x 460H x 100D	SP4304
	D255	830W x 770H x 100D	SP4310
	FD500	Side Pads (Filtros laterales) 928W x 960H x 100D	SP4544
	FD500	Front/Back Pads (Filtros frontales y traseros) 645W x 960H x 100D, cada unidad:	SP4546

<b>2003 - 2011</b> <b>CONJUNTOS DE FILTROS COMPLETOS SEGÚN MODELO</b>	QA 160D Y QA 230 D. 4 Filtros	
	QA 255 D Y QA 255 TOP. 4 Filtros (830x770x100)	
	QA 240 S 3 Filtros (830x950x100)	
	QA 240 M 3 Filtros (830x950x100)	
	QA 500 D 6 Filtros	
	QA 100S 3 Filtros	

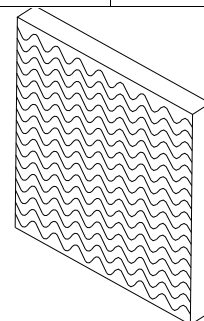

\* Height includes 30 mm Top Water Distribution

# LOUVRE PANELS (REJILLAS DE PROTECCION y BASES)

Precios unitarios/INDIVIDUALLY PRICED

Manufactured	Model & Description	Part No.
<b>Louvre Panels</b> - Specify Colour (Especificar el color)		
1994 - 2000 <b>Serie CM, color gris.</b> <b>C100 S, color beige.</b>	130	SP0055
	185	SP0059
	Side Discharge 100S front louvre (Rejilla frontal)	SP0063
	Side Discharge 100S side louvre (Rejilla lateral)	SP0065
	Side Discharge 200S/240S y CM250 D (gris)	SP0063
	Mobile Unit CMP200	SP0063
	Rejilla frontal M240S	SP9609
<b>Series V,CA, TOP and FD500 Color beige Heritage</b> 2000 - 2011	D160 (color beige)	SP0068
	D255 (color beige)	SP0074
	FD500, Side Louvre (Rejilla lateral)	SP0534
	FD500, Front/Back Louvre (Rejilla frontal y trasera)	SP0535
	BASE QA 255D	SP1009
	BASE M240S	SP1080
	BASE QA 500D	SP1530

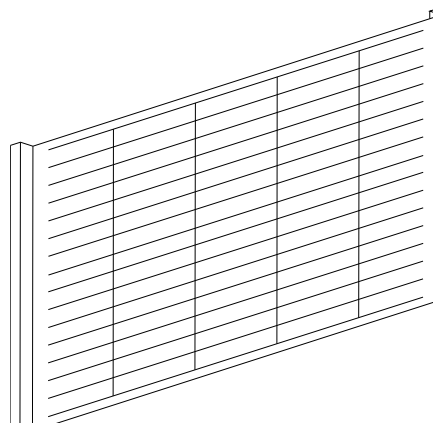

**WATER DISTRIBUTION PARTS (PIEZAS DE LA DISTRIBUCION DE AGUA)**  
**Precio por pieza/INDIVIDUALLY PRICED**

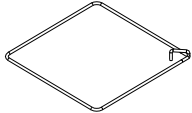
Manufactured	Model	Description	Part No.
<b>Water Manifolds (Distribuidor del agua) Formado por 4 tubos</b>			
<b>Series V, CA, TOP y Side (S) Heritage</b> 2000 - 2011 	100S	Water Manifold (Distribuidor del agua)	SP2009
	Todos los modelos con 4 filtros	Water Manifold -black elbow (Codo color negro)Tubos perforados hacia abajo	SP2007
	240S M240 Mobile	Down Discharge on three sides (Descarga por 3 lados)	SP2011
	FD500 (Twin	Water Manifold (Tubos de dis-	SP2530

**Water Feed Pipes (Tubo de alimentacion de agua)**





<b>Series V, CA, Top Side FD 500 (Twin)</b> 2000 - 2011 Es el tubo que va de la bomba al distribuidor de agua 	CA 100 S	980mm	SP 2097
	D160	510mm	SP2102
	D255	820mm	SP2108
	FD 500	Front Feeder 950mm (Tuberia frontal)	SP2544
	FD 500	Back Feeder 1010mm (Tuberia posterior)	SP2546
	240 S	1000mm	SP2098
	M 240 Mobile	1140mm (Raiser Pipe Kit)	SP2116

**Tapas superiores Evaporativos**

<b>Series V, CA, TOP y Side (S) Heritage</b> 2000 - 2011	100S	Tapa superior del evaporativo	SP1054
	255D 240S	Tapa superior del evaporativo	SP1010B
	M240 Mobile	Tapa superior del evaporativo	SP1010Mo bile
	FD500	Tapa superior del evaporativo	SP1532

# WATER INLET & DISTRIBUTION PARTS (Piezas de la toma y distribucion de agua)

Precio por pieza/INDIVIDUALLY PRICED

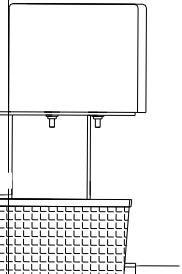
Manufactured	Description	Part No.
<b>Solenoids and Accessories</b>		
2002 - 2011	24v Barbed Solenoid - suits unit with Counter Weight drain valve Electrovalvula para todos los modelos (con desague por contrapeso)	SP2031
	Flexible Connection (Braided) Heritage Manguito flexible	SP2061
	Through Sump Elbow & Bracket - c/w 'O' ring Codo de entrada de agua con soporte y junta torica	SP2039
	Drain Fitting Female 20 to 40mm	SP2073
	Tap and filter (Llave de paso con filtro en Y)	SP2076
	<b>and Accessories (Bombas de agua y accesorios)</b>	
	Quietflo long shaft - to suit Mobile M240 2002 - 2004 (Bomba de agua Quietflo con eje largo para el M240 Movil)	SP2035
	Ziehl Pump	SP2123
	Capacitor 1 uF - Zeihl Pump capacitor	SP2122
	Fasco JRM E/P 38 Pump -with 1400mm long lead	SP2127

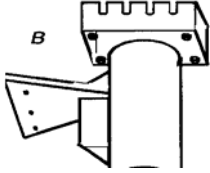
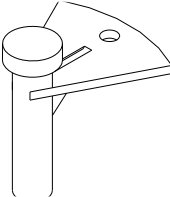
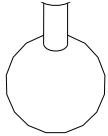
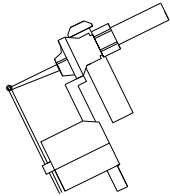
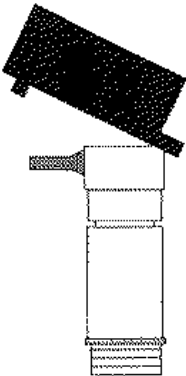

# WATER INLET (Piezas de la entrada de agua)

Precios unitarios/INDIVIDUALLY PRICED

Manufactured	Description	Part No.
<b>Float Valve and Accessories (Flotadores y accesorios)</b>		
	<b>MWL Control Unit</b> <ul style="list-style-type: none"> <li>MWL Magnetic Water Level - to suit Twin Fan (FD500) (Refer to Diagram 2 section B)</li> <li>Control MWL Magnetico del nivel de agua, para FD 500 (Twin Fan) (Pieza B de la figura 2)</li> </ul>	SP2210
	<b>MS Control Unit (Magnetic Sensor)</b> Level - to suit CA series (Refer to Diagram 2 section B) <b>Control MS (Sensor Magnetico)</b> Controla el nivel de agua en los evaporativos de la Serie CA (Pieza B de la figura 2)	SP2212
	<b>Magnetic Float Assembly</b> - Compatible with MS and MWL control units. (Refer to Diagram 2 section A). <b>Flotador Magnetico.</b> Este flotador es igual para los dos controles MWL y ML (Pieza A de la figura 2)	SP2200
	Fluidmaster Float 747 - Mobile unit	SP2027
<b>Drain Valve and Accessories</b>		
2001 - 2011	<b>Counterweight Drain Valve Kit</b> - including blue square section washer - excluding hose kit <b>Conjunto de la valvula de drenaje por contrapeso</b> (EL Kit incluye la arandela de seccion cuadrada pero no los tubos de goma, que se suministran por separado)	SP2040
	<b>Hose Kit</b> - to suit counterweight drain valve Kit de tubos de goma de recambio (para conectar a la valvula de drenaje)	SP2042
	<b>Plastic Clips</b> - for securing counterweight hoses Clips de plastico para los tubos de goma	SP2041
	<b>Counterweight Drain Valve Washer</b> - blue square section (Arandela azul, de seccion cuadrada para la valvula de drenaje)	SP2066C

# FANS AND MOTORS (Ventiladores, motores y sus accesorios)

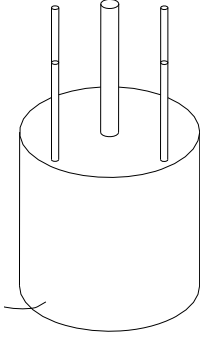
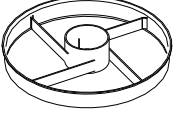
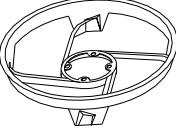
Precios unitarios/INDIVIDUALLY PRICED



Manufactured	Description	Part No.
<b>Motors and Accessories (Motores y sus accesorios)</b>		
	Motor 600w (only motor) (Solo el motor)	SP6012
	Motor 750w, only	SP6014
	Motor 1000w, only	SP6015
	Motor Lead to Electrical Box extension (Cables de connexion entre el motor y la caja de conexiones)	SP6020
	Motor Lead to Electrical Box extension QAD500, FD500 & Top discharge (Cables de connexion entre el motor y la caja de conexiones)	SP6070
	Motor Mounting Grommet kit (Juego de arandelas de goma del motor)	SP6024
1994 - 2011 	Motor Mounting Ring 524 mm dia. black plastic (Anillo exterior soporte del motor, en plastico negro) Para FD 500, QAD500 CA 240S & 100S, Top 255	SP6022
2002 - 2011 	Shrouded Motor Mounting Ring 530 mm, black plastic Anillo exterior envolvente de 530 mm diametro, con nuevo diseno, en plastico negro. Para CA 255D.	SP6025
2002—2011	Capacitor 25uF (Condensador 25 mF)	SP3039
2002 - 2011	Capacitor 30uF (Condensador 30 mF)	SP3040
	<b>Motor Pack 1000 w. shrouded</b> (include axial fan 530 mm. dia. and ring assembled), for CA 255 D. <b>Motoventilador completo 1000 w.</b> (incluye el ventilador axial de 530 mm. y el anillo de soporte. Para CA 255 D.	MP1000S
	<b>Motor Pack 1000 w. for Twin Fans FD 500, Side and Top discharge unit</b> (include axial fan 524 mm. and ring assembled). <b>Motoventilador completo para FD 500, CA 240S y Top.</b> (incluye el ventilador axial de 524 mm. y el anillo de soporte)	MPX1000

# FANS AND MOTORS (Ventiladores, motores y sus accesorios)

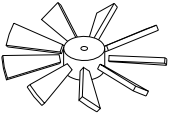
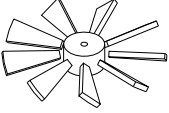
Precios unitarios/INDIVIDUALLY PRICED

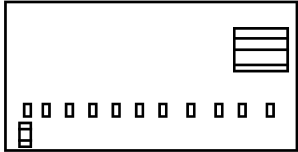

Manufactured	Description	Part No.
<b>Fans and Accessories (Ventiladores, helices y sus acceso-</b>		
2000 - 2011	 <p><b>524 mm Diameter 10 blade</b> Variable Pitch Fan - grey colour blades and green hub - suited to 600w motor (CA 150D) on 100S units <b>Helice axial de 524 mm. diametro, con 10 palas regulables,</b> - palas color gris y moyu verde. Se</p>	SP6027
	<p><b>524 mm Diameter 9 blade</b> Fixed Pitch Fan - Black colour- suited to 1000w motor on Twin Fan FD 500, QAD500, CA 240S, and Top 255 <b>Helice axial de 524 mm. diametro, con 9 palas fijas,</b> de color negro, se monta en el motor de 1000 watos</p>	SP6031
2002 - 2011	 <p><b>530 mm Diameter 10 blade</b> Variable Pitch Fan - Grey colour. To suit units with 750 watt motor (CA 160D) <b>Helice axial de 530 mm. diametro con 10 pa-</b></p>	SP6054
	<p><b>530 mm Diameter 9 blade</b> Fixed Pitch Fan Black Colour to suit units with 1000 watt motor (CA 255 D) <b>Helice axial de 530 mm. diametro,</b> con 9 palas fijas, color negro y se monta en el motor de 1000 watos del CA</p>	SP6056
1992 - 2011	Fan collet & Bolt fixing pack to suit <b>10 blade</b> variable pitch fan (Kit de mordazas de apriete y tornillos para	SP6043
2000 - 2011	Fan collet & Bolt fixing pack to suit <b>9 blade</b> fixed pitch fan.(Kit de mordazas de apriete y	SP6047

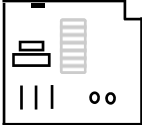
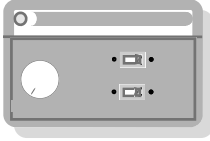
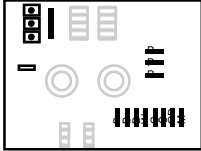
# CIRCUIT BOARDS & CONTROLLERS (Circuitos electronicos y cuadros de control)

Description	Part No.
<p><b>F, FC SERIES</b></p>  <p><b>CFRU ROOF UNIT</b> for Twin Fans FD 500 <b>PLACA ELECTRONICA</b> para FD 500.</p>  <p><b>R Controller</b> - replaced F Series controller - Twin Fan Unit</p>  <p><b>Keypad Signal Booster Board</b></p>	<p>SP3510</p> <p>SP3504</p> <p>SP3512</p>
 <p><b>Tek298 240V Roof Unit ,</b> <b>Placa electronica para</b> <b>Modelos CM</b></p>  <p><b>Tek285 Cuadro de</b> <b>control para CM</b></p>	<p>SP3014</p> <p>SP3016</p>
 <p><b>Mobile Control Unit</b> Complete with box M240 <b>Cuadro de control</b> para M 240 Movil</p>	<p>SP3013</p>

# CIRCUIT BOARDS AND CONTROLLERS (Circuitos electronicos y cuadros)

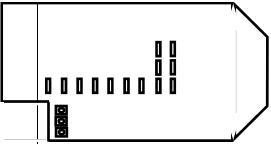
Precios unitarios/INDIVIDUALLY PRICED

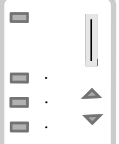
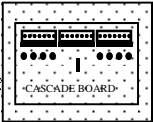
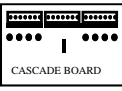
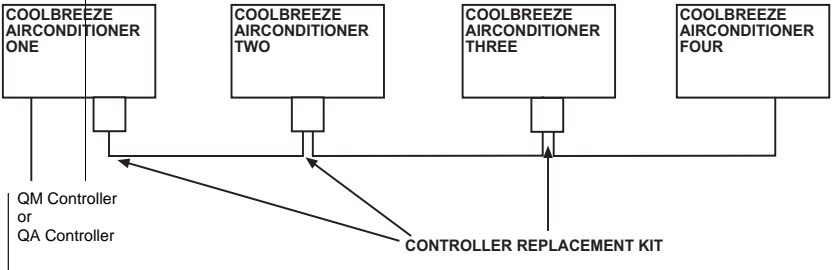
Circuit Boards and Controllers (Circuitos electronicos y cuadros de control)	Part No.
<p><b>D SERIES</b></p>  <p><b>Modular Roof Unit (MRU)</b> circuit board for CA &amp; QA Series.</p>  <p><b>QA-RS Speed Controller REMOTE SHUTDOWN</b> (Cuadro con posibilidad de marcha/paro a través de señal externa remota)</p>  <p><b>QA Automatic 100 Speed Controller</b> Control por velocidad y temperatura Automático</p>  <p><b>QM 10 Speed</b> Control solo por velocidad Manual</p>	<p>SP3000</p> <p>SPQARSC (MANDO+CABLES)</p> <p>SPQARS (SOLO MANDO)</p> <p>SP3221</p> <p>SP3220</p>
<p>Cascade Circuit Board - to be fitted in secondary electrical box in Twin Fan QAD500 (Controller Replacement Circuit Board) - Fitted in electrical box of twin fan units Placa de interconexión entre las dos placas principales de los equipos QA 500 D.</p> 	<p>SP3007</p>
<p>Cascade Circuit Board - Fitted in housing (Controller Replacement Circuit Board) - used to control more than one unit using only one keypad. Use on single fan units eg. D255. Placa de recambio para los kits de cascada con carcasa.</p> 	<p>SP3008</p>
<p><b>Cascade Kit - Operates more than one unit (Single/Twin Fan Unit) off one controller.</b> Suits QA or QM Kit de Cascada para conectar más de una unidad con un mismo mando. Compuesto por placa de cascada y cables de interconexión. Sirve con mandos QA y QM (Mando no incluido)</p>  <p>COOLBREEZE AIRCONDITIONER ONE</p> <p>COOLBREEZE AIRCONDITIONER TWO</p> <p>COOLBREEZE AIRCONDITIONER THREE</p> <p>COOLBREEZE AIRCONDITIONER FOUR</p> <p>QM Controller or QA Controller</p> <p>CONTROLLER REPLACEMENT KIT</p>	<p>UAKSKT</p>

## CONTROL CABLES AND ELECTRICAL BOXES (Cables De Conexion)

Precios unitarios/INDIVIDUALLY PRICED

Multi-Core control cables (Cables de connexion y	Part No.
Keypad cable 15m - 7-core with 2 female ends (Cable de 15 m. para la connexion del cuadro de mandos (CA y CPF). Tiene 7 hilos y 2 terminals hembra	SP5200
Keypad cable extension 10m - 7-core with 1 male end and 1 female end (Cable de prolongacion de 10 m. Permite prolongar el cable del cuadro de mandos. Tiene 7 hilos y 1 terminal macho y 1 terminal hembra)	SP5206
Electrical Box connector cable for FD 500 (Twin Fans) - 3..2 m. x 7 core with 2 female ends. (Cable de connexion entre las 2 cajas interiores del FD 500 —tiene 7 hilos y 2 terminals hembra)	SP5223
Mains cable 3 metres x 3 core European plug	SP5225
Printed Circuit Board connector cable for D 500 (Twin Fans) - 200m x 7 core with 2 female ends. (Cable de connexion entre las 2 cajas interiores	SP5224
Motor Lead to Electrical Box extension (Cables de connexion entre el motor y la caja de conexiones)	SP 6070
Caja de plastico negra de proteccion para places SP 3000 y SP 3510	

# BOMBA DE AGUA ZEIHL

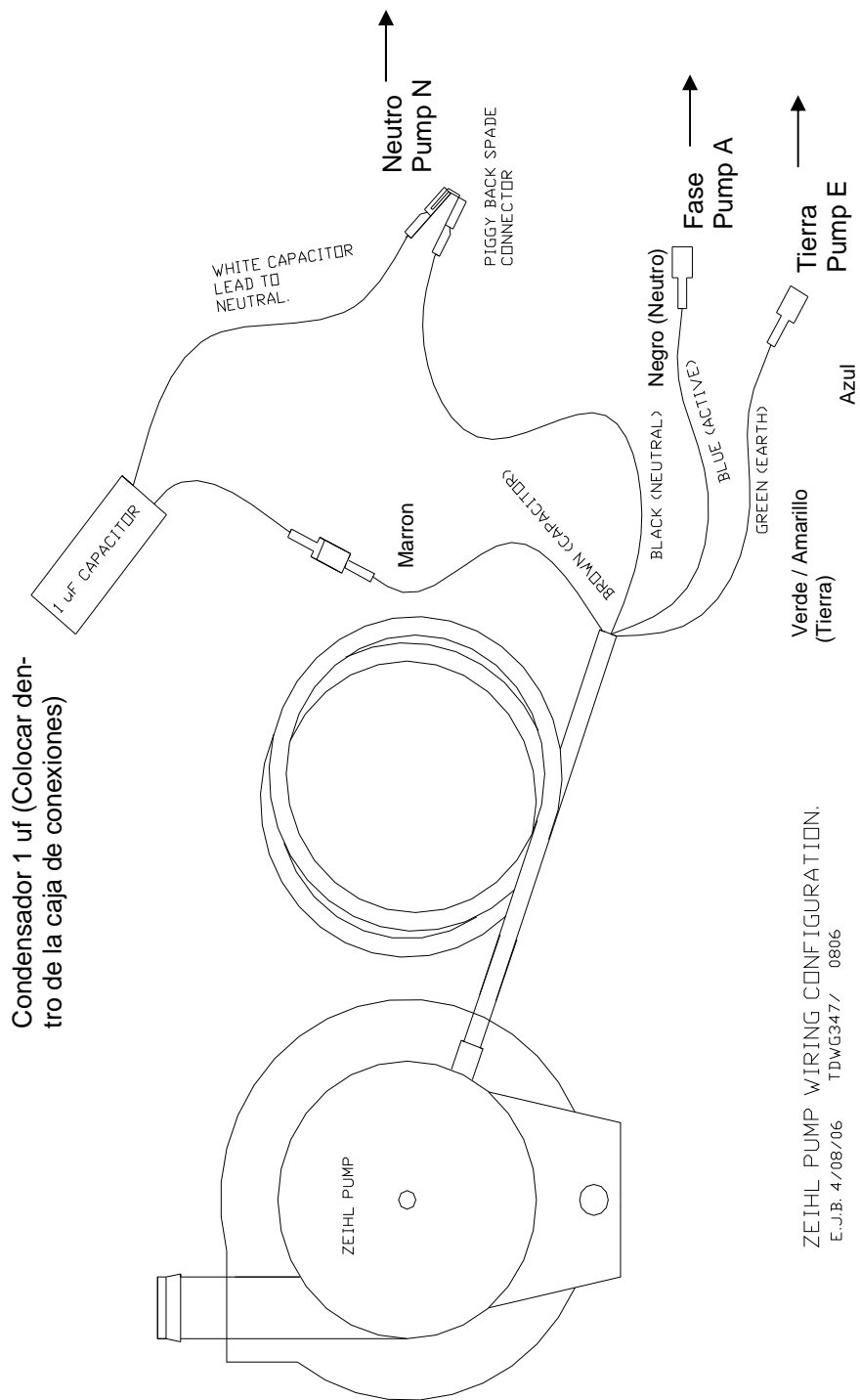

Condensador 1 uf (Colocar dentro de la caja de conexiones)

ZEHL PUMP WIRING CONFIGURATION.  
E.J.B. 4/08/06 TDWG347/ 0806